

TEL AFA 1000/2 MK2 FUME HOOD MONITOR — INSTALLATION AND OPERATION GUIDE

STARTUP

The AFA 1000/2 must be field-calibrated after an HVAC professional balances the room air supply and exhaust. Each unit is shipped with a yellow sticker covering the display panel. This sticker must be removed before calibration. If the sticker has been removed and the unit still needs to be calibrated, use the following calibration instructions.

CALIBRATION

1. Press and hold the ENTER button to bring up RUN/SET UP menu.
2. Using the +/- buttons, select SET UP, then select CALIBRATION, then enter the password (the default password is 0-0-0-0; press the ENTER button four times to proceed to the next step).
3. Open the sash to the normal operating height and measure the face velocity with a calibrated instrument. Use the +/- buttons to input the measured value, then press ENTER and wait as the unit takes an air sample.
4. Lower the sash by half and again measure the face velocity with a calibrated instrument. Use the +/- buttons to input the measured value, then press ENTER and wait as the unit takes an air sample.
5. If calibration is successful, select DONE. You will return to the RUN/SET UP menu. Select RUN and the monitor will switch to normal operating mode, displaying the face velocity.

TROUBLESHOOTING

Problem	Check For
No lights	<ul style="list-style-type: none"> • Power cord plugged securely into monitor • Power supply plugged into outlet • Correct voltage to outlet
Red light on, no alarm sound	Unit is in "permanent horn silence" mode. (Display should show picture of a horn crossed out). Horn may be re-enabled in Cal Configure menu.
Velocity displayed does not match anemometer	Air patterns in the room may have changed since last calibration. Re-calibrate per owner's manual instructions.
Calibration tips	<ul style="list-style-type: none"> • Make sure hose is connected properly at the side-wall and to the rear of the monitor. If disconnected, reconnect and calibrate again per the owner's manual. • Make sure fan is running and air is being exhausted through the hood. • Take extra time (at least 15 to 20 seconds, more on larger hoods) to wait for the airflow to settle between capturing the low velocity reading (sash high) and the high velocity reading (sash low). This will minimize the chance for a calibration error due to excessive fluctuations. • Avoid movement around the hood while sensor is taking its air sample. • High air value and low air value must be different by at least 60 fpm. This parameter can be adjusted in Cal Configure menu. • Do not use fully open and fully closed as the two calibration points, except when working with bypass hoods. With bypass hoods, recommended positions are full open for the low velocity reading, and for the high velocity reading, open the sash to where the top just covers the bypass opening. • Hoods already under VAV control require two different setups for a calibration: "normal" exhaust for the low reading and "purge" or max exhaust for the high reading. Suggested values are 100 fpm and 300 fpm respectively.

MONITOR PANEL CUTOUT DIMENSIONS

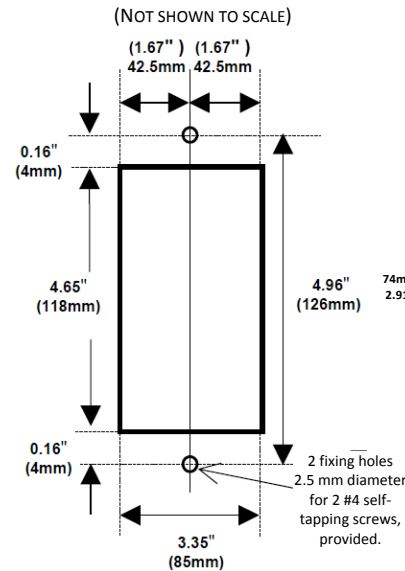

SM6 SENSOR DIMENSIONS (REAR VIEW)

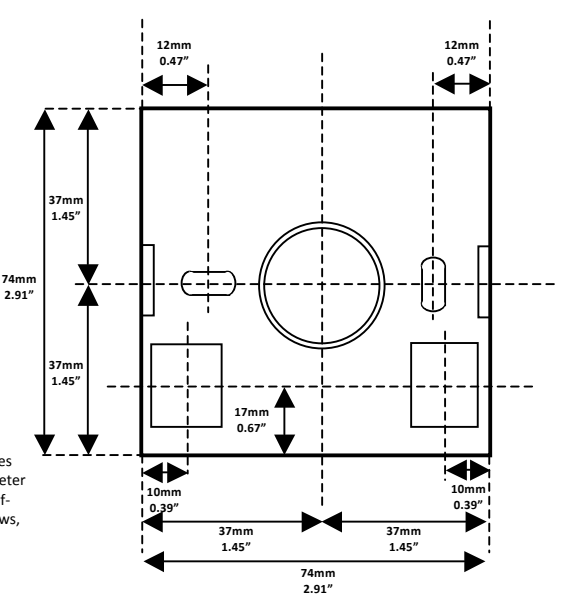

ALARM PANEL DIMENSIONS

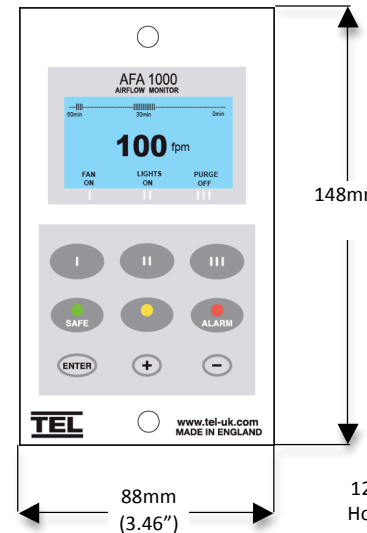

SM6 PANEL CUTOUT DIMENSIONS (FRONT VIEW)

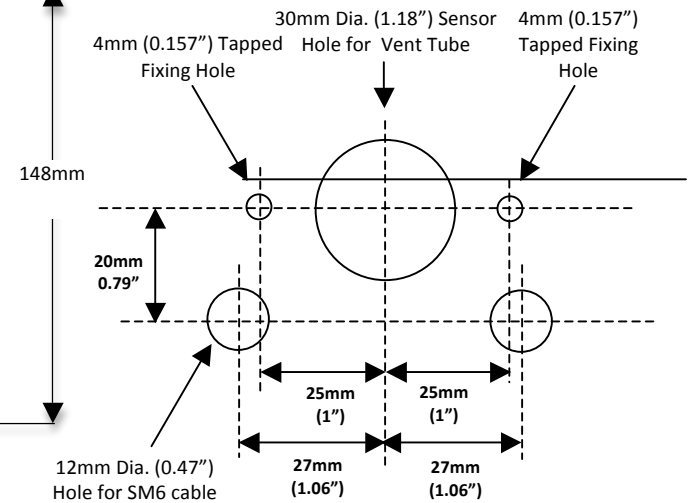

TEL AFA 1000/2 MK2 FUME HOOD MONITOR — INSTALLATION AND OPERATION GUIDE

CONNECTION DETAILS

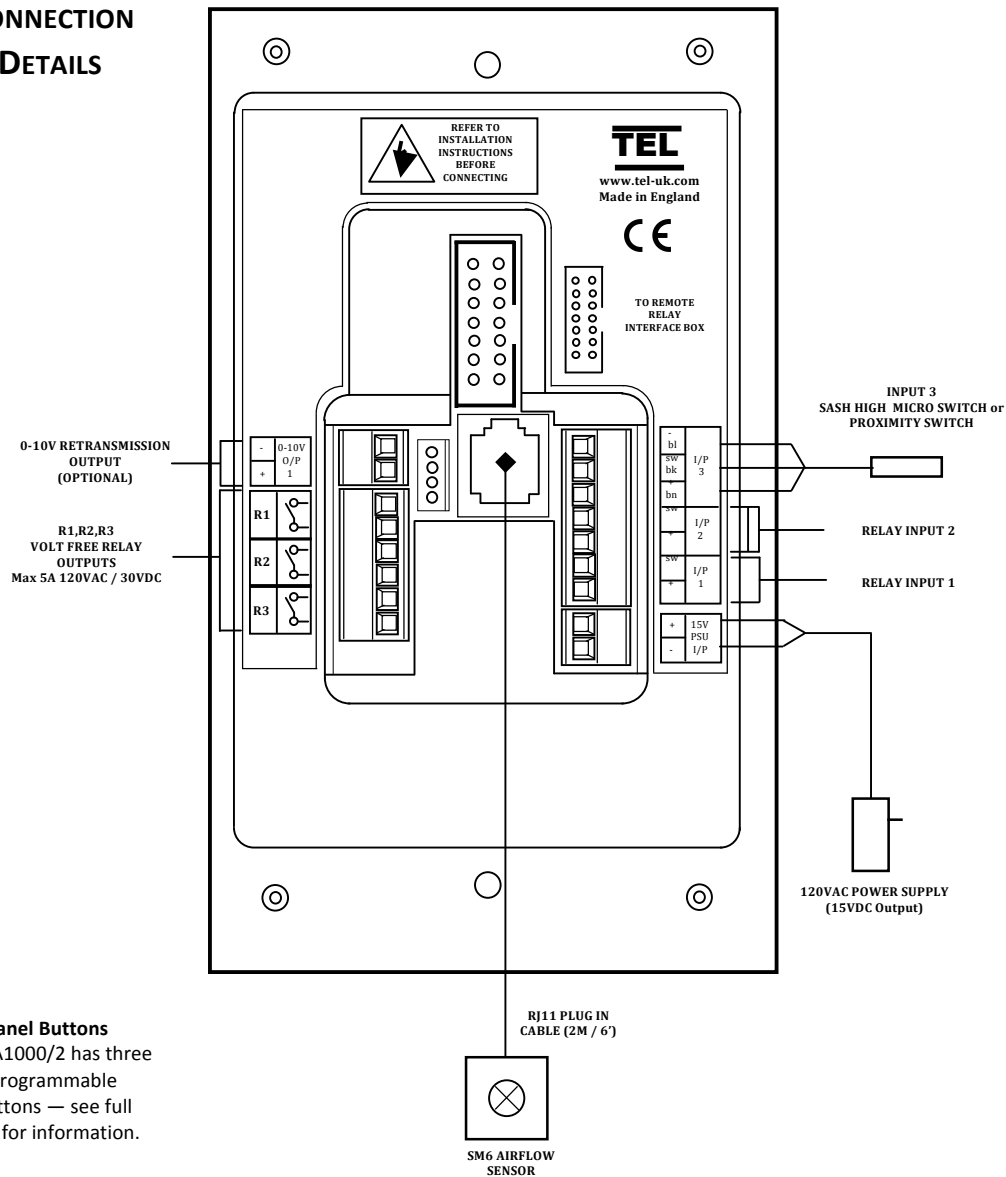

Front Panel Buttons
The AFA1000/2 has three menu-programmable pushbuttons — see full manual for information.

FRONT POST INSTALLATION

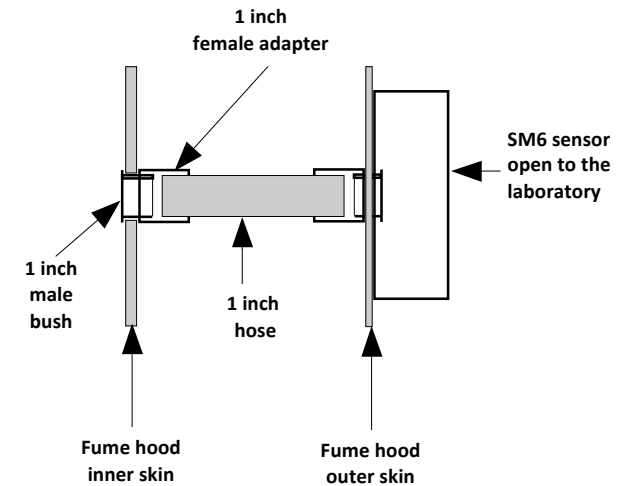

SIDEWALL SENSOR PLACEMENT

The monitor must be positioned where it can "see" the room pressure of the laboratory. The back connection spigot of the monitor will accept the provided air hose, which should be connected to the inner chamber of the fume hood. The **ideal position** for the other end of the hose, for most fume hoods, is 100mm (4 inches) back from the sash and 100mm higher than the normal sash opening height through the inner side wall.

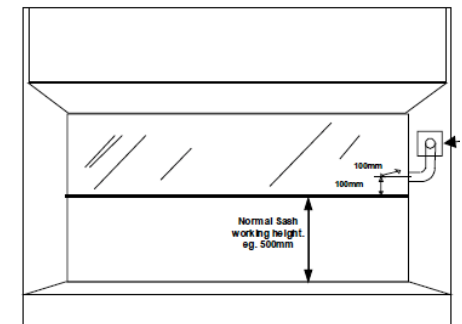

Mount the monitor on the front of the fume hood and use the provided hose. For fume hoods with a single skin side wall or a double skin with a small gap between them, it may not be possible to achieve the ideal sensing position using the provided hose. With a single skin side wall it is possible to fix the sensor on the outside of the fume hood and connect directly to the inner chamber in the ideal position. This method can only be used for up to two fume hoods when they are positioned side by side (using the two outer walls).

The sensor should not be mounted in a position where it is subject to drafts from the laboratory air input or ventilation system.